

# **Final Report**

Digital Cantilever Systems

Team 17

*Team Leader: Rocco*

*Team Members: Justin, Edwin, David, and Daniel*

12-10-99

\* \* \* \*

## **Executive Summary**

Team 17's objective was to conceptualize and construct a functioning postal scale that meets the required specifications detailed in the project assignment. We planned to complete this task by designing a digital scale which used several integrated subsystems. Certain problems which were addressed during the course of this assignment included the binding of moving parts, friction between parts, and even weight distribution.

Our cantilever design concept limited the amount of moving parts, thus eliminating any problems with friction and binding. To assure that the accuracy specification was met, we used a four-cantilever system. We chose to use four beams placed at each corner of a weighing platform to provide for even weight distribution and to allow the scale to measure weight at any given point on the platform.

Our design uses the least amount of parts possible, and consequently will save time and money in machine work as well as assembly time. Additionally, this aspect of our design improves reliability, durability, and longevity. With all of the above features and specifications in mind, Team 17 set out to produce a scale that would perform with exceptional standards and be appealing to the consumer.

## **Introduction**

Team Seventeen's initial assignment was to design and build a working prototype digital postal scale that meets required design specifications outlined in Table 1. The three most important qualities of the prototype are as follows: First, the scale must hold up to 4 lbs, have a resolution of ½ an ounce, and weigh with an accuracy of no more variance than +/- 0.5%. This made it important that Team 17 would have to design a system which would be strong enough to weigh four pounds while still being sensitive enough to weigh as little as ½ an ounce. Additionally, the scale must be within a margin of several ounces at its four-pound maximum. These characteristics will give the scale versatility with the ability to weigh an average envelope up to a four-pound package. The scale itself is limited in size: it must fit within a 15"X8"X5" box while disassembled. A power source of no more than two nine-volt batteries must power the scale. Finally, the entire development process is restricted by a budget of \$25 per team member, for a total of \$125.

<i>Requirement</i>	<i>Specification</i>
Capacity	0-4lbs
Resolution	.5 ounces
Accuracy	0.50%
Display Readability	2 feet
Platform Size	Holds 1 standard envelope
Power Source	two 9-volt batteries
Size	Fit in a shoe box
Assembly Time	50 Min
Disassembly Time	15 Min
Cost	Under \$125.00

**Table 1, Design Specifications**

### **Prototype Description and Principles of Operation**

In order to produce a product able to satisfy the given specifications, team 17 devised a design concept consisting of four main subsystems: 1) weighing platform; 2) strain beam assemblies; 3) housing; and 4) electronics.

**Figure 1, Platform**



The platform, measuring exactly 6"x6" (see Figures 1 and 7), resembles an inverted box with an open bottom with its sides measuring one inch tall. It is constructed of 1/16" thick aluminum and is completely welded with epoxy at all joints, making it able to support a four pound package while still being light so as not to place unneeded stress on the strain beam system. The object to be weighed is set upon this platform, which now performs two roles: collecting the total weight of the object and transferring this force to single points on four strain beams underneath.

This one-piece design does not require additional guides or mounts due to its precise fit within the scale housing. The sides of the platform are polished to decrease friction with the housing edge, which acts as a guide. The platform sits on four strain beams, each in the form of a cantilever. The cantilever beam assemblies (see Figures 2 and 5) convert the downward force of the object being weighed into compression or tension forces, in addition to supporting the platform. One beam is placed at each corner of the platform to provide for even weight collection and consequently, improved accuracy. Each cantilever beam represents two-point bending, similar to a diving board, because it is supported at one point while force is applied to the other. These beams measure 3 ¼"X ½"X 1/16" and are made from 6061 T6 aluminum. This material with these dimensions will allow for sensitivity as well as a safety factor greater than two. The electronics of the scale come into play at this point. Two strain gages are placed on top of two beams to measure tension forces, while two more strain gages are placed below two beams to measure compression forces. As the strain gages are compressed or

stretched, their resistance values change. The electronics are designed in order to convert the strain placed on the four beams into a voltage corresponding linearly with the weight of the object being weighed. This voltage is displayed on an LCD display (see Figure 3). The circuit is powered by 18 volts (two nine-volt batteries wired in series) and consists of a Wheatstone Bridge and an LM741 Operational Amplifier, in addition to various resistors and accompanying wiring (See Figure four for circuit placement and appendix for schematic). The scale housing is constructed of poplar and measures exactly  $12 \frac{1}{2} \times 6 \frac{1}{2} \times 2 \frac{1}{4}$  inches, allotting plenty of space for the internal electrical components while still satisfying our size specifications (see Figures 3 and



Figure 2, Cantilever Assembly

6). This size easily accommodates a large enough weighing pan to be able to successfully weigh a 4 lb. package. For pleasing aesthetics, the housing will be finished with a wood stain.

*Assembly* (refer to Figures 4 and Table 2 for parts list)

To construct Team 17's scale prototype, the following steps were followed:

and allow it to sit overnight. c. Polish the four sides of the platform using fine-grit sandpaper.

2) **Cantilever beam assembly-** a. Bond strain gages to beams using appropriate adhesive. Be sure to mount in correct position (see Figure 5). b. Obtain (4)  $1'' \times 1'' \times \frac{1}{2}''$  aluminum blocks and (8)  $1'' \times 1'' \times \frac{1}{8}''$  aluminum plates. c. Clamp aluminum block, strain beam, upper support plate, and bottom shims using C-clamp and drill two holes with  $\frac{5}{32}''$  drill bit (see Figure 5). Set aside.



Figure 3, Top View of Complete Scale

3) **Housing assembly-** a. Obtain the seven poplar pieces as shown in Figure 3. b. Screw together all but top portions using #4  $\frac{1}{2}''$  brass screws.

4) **Electronics assembly-** a. Construct circuit using parts outlined in Table 2 and following schematic (Figure 9). b. Solder wires to appropriate strain gages.

5) **Final assembly-** a. Place completed cantilevers in each corner of the housing and screw through base, shims, blocks, beams, and upper support plates using  $2 \frac{1}{2}''$  machine screws (see Figure 3). b. Mount electronics breadboard in center of housing onto base. c. Attach brass hinges to the top housing pieces and sides of housing. d. Mount four nylon feet to bottom corners of base. e. Remove multimeter from its housing and mount to underside of left upper housing piece. f. Place platform onto cantilevers.

## Analysis and Testing

Once the prototype was complete, it was tested using several weights. Our data was then compared to calculated results (see equations in appendix). Testing revealed the following: As expected, the four cantilever assemblies provided for excellent weight collection. Only a small variance was noted between different weight positions on the platform. The dimensions and material of the beams also proved to be ideal for smaller measurements, as was seen while

weighing in increments of 1/2 ounce.

As seen in the graph (see graph 1), error between the actual and calculated outputs increases as the amount being weighed increases. This is due to the fact that the op-amp will amplify error linearly with the amount of volts being amplified. This error can also be attributed to several things: friction between the platform sides and the scale housing; voltage loss through the circuit; and low battery output.

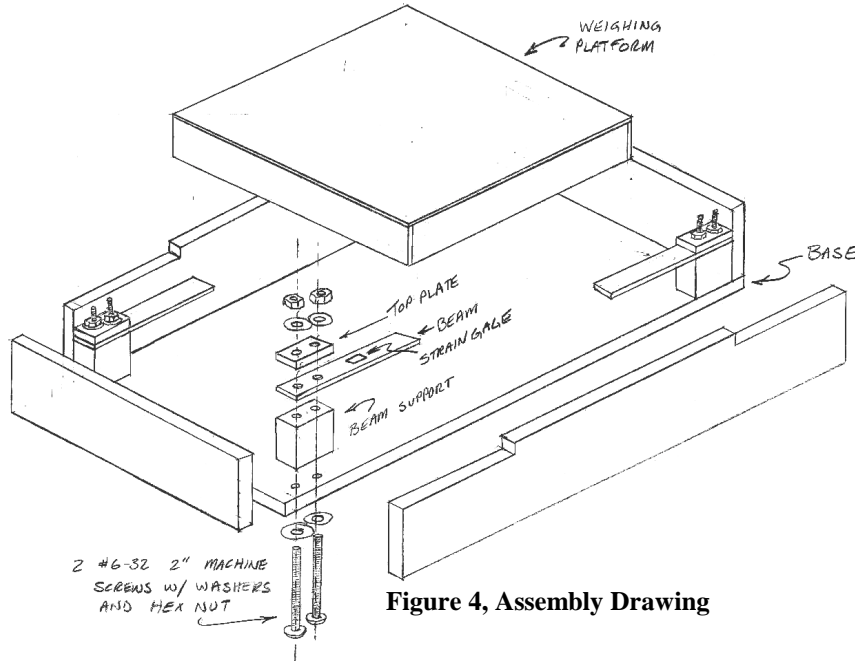

Figure 4, Assembly Drawing

Part	Description	Quantity	Cost
12x6x.0625 Al Plate	Weighing Platform	1	\$5.75
J-B Weld	Platform Glue	1	\$2.96
12x6x.0625 Al Plate	Sensing Beams	1	\$5.75
1x1x.5 Al Blocks	Beam Supports	4	\$8.00
2x4x.25 Poplar	Casing	1	\$5.00
Nylon Feet	Casing Feet	4	\$1.97
Brass Screws	Casing Screws	20	\$1.98
2x3.5 Breadboard	Circuit	1	\$6.99
120 ohm Strain Gages	Strain Gages	4	\$8.00
#6-32x2" Machine Screws	Sensing Beam Supports	8	\$5.94
9-volt Batteries	Power	2	\$3.99
9-volt Battery leads	Power	2	\$0.50
10,000 ohm multi-term Potentiometer	Zeroing Tool	1	\$1.50
Lm-741 Op-Amp	Amplifier	1	\$0.79
120 ohm Resistors	Circuit	2	\$0.50
5.6k ohm Resistor	Circuit	1	\$0.25
47k ohm Resistors	Circuit	1	\$0.25
22 Gauge Wire	Wire	1	\$0.29
Voltmeter	Circuit	1	\$8.00
On/Off Switch	Circuit	1	\$2.00
Brass Hinges	Casing Hinges	4	\$4.00
Total Cost of Finished Model			\$74.41
Miscellaneous Items	Mistakes, etc.		\$25.00
Total Cost of Project			\$99.41

Table 2, Parts List

during testing the two nine-volt batteries was less than 18 volts, and actually measured 14 volts. Graph 1 illustrates how this lessens the error between actual and calculated measurements.

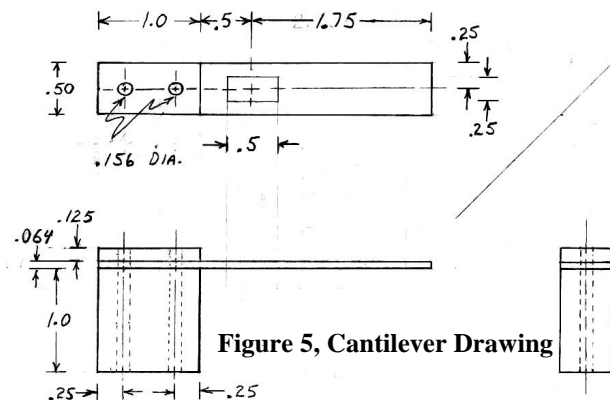

Figure 5, Cantilever Drawing

## Project Management

Needless to say, money was a large issue throughout the development process. In order for Team 17 to produce an appealing product we had to select quality parts and keep the price low. This was accomplished through designing a product with a very low number of parts. Not counting the circuit, our prototype can be made from two materials and only 23 parts in addition

**Figure 7, Platform 3-view**

to fasteners. These parts required only very basic machinework and time to produce which lowered Team 17's costs.

Saving time also saves money, so management and organization was stressed throughout this assignment. Equal effort and time from each member was put into the development of our

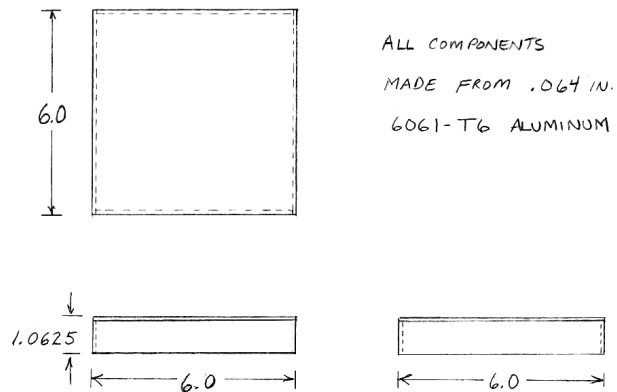
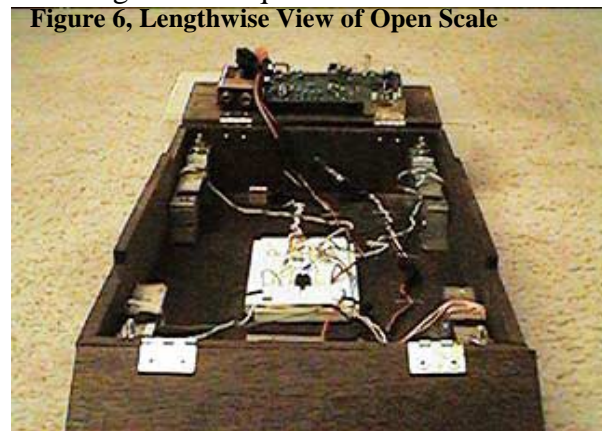

digital postal scale prototype. All deadlines were met and we were always on task, even if we found ourselves up until 5:00 in the morning. To optimize our time, we split the construction of the prototype into several stages performed by different members: aluminum machining, platform assembly, cantilever assembly, circuit assembly, and housing assembly. These tasks were being performed simultaneously, thus decreasing the time in production. Final assembly was performed by all five members of Team 17, as was the testing phase. Throughout the assignment, each member provided useful and constructive information as can be seen in the finished product.

### Summary and Recommendations

When comparing target specifications to actual test specifications, one can see that Team 17's

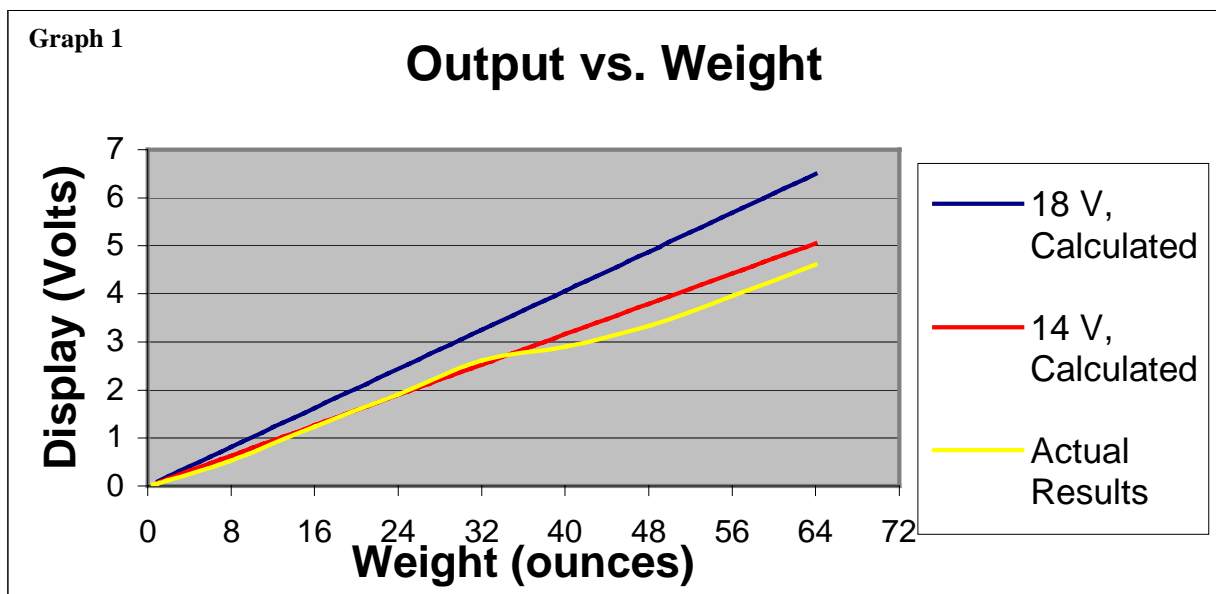

scale met each one, especially while in the lower weight range. However, accuracy seemed to

suffer past the two pound point, as can be seen in graph 2. Team 17's unconventional design revealed many advantages as expected. First, even weight transfer was not a problem with the four cantilever system. The display varied only minimally while moving weights across the surface of the platform. Second, the low number of parts and the fact that there are no moving parts or metal-to-metal contact increases the life of our scale and makes it very low maintenance. Lastly, the scale is compact and its price is relatively inexpensive, rivaling competitors with its quality for a low price.

Although Team 17 was able to overcome most difficulties in this assignment, two problems seemed to have plateaued in their improvement. First of all, we often scheduled less time than needed for tasks that needed to be complete. This led to late and tiring nights where we were still able to produce quality work. Along with sub-nominal time management, we

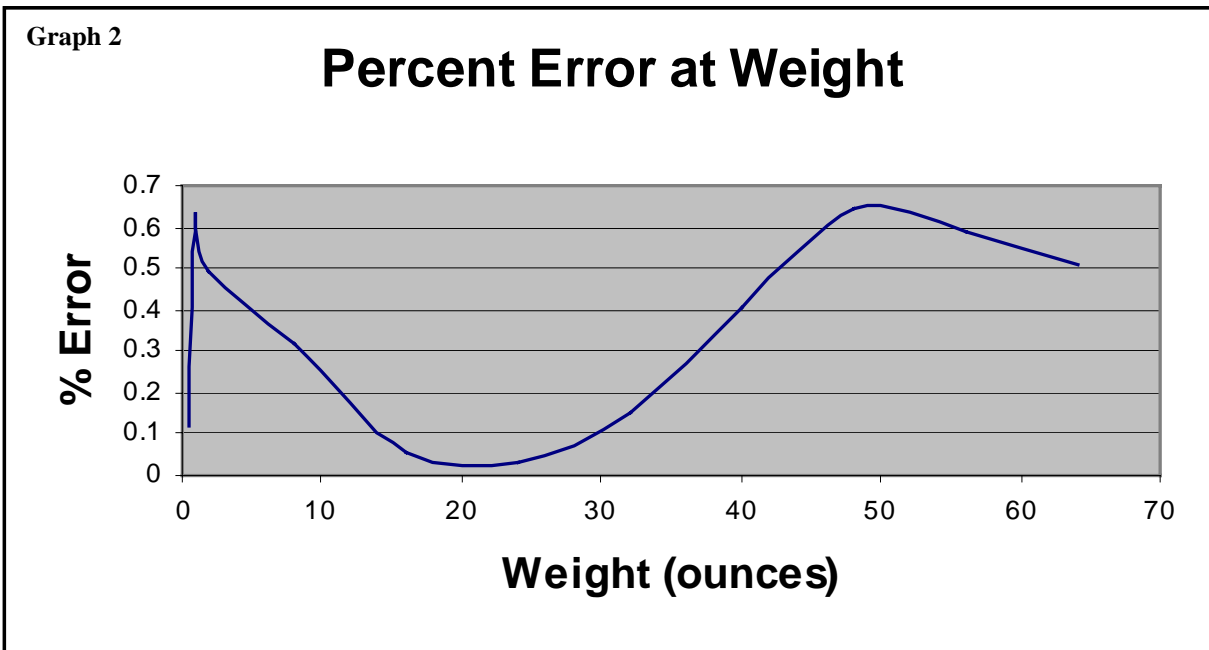

suffered with communication amongst members. Improvement in these two aspects of our assignment would have relieved stress and made us a better team all the way around.

Several disadvantages have been noticed through long-term testing. The poplar wood used to construct the scale housing is subject to warping and the aluminum strain beams may fatigue over time causing inaccuracies. These two disadvantages of Team 17's design could easily be changed in a production model, however. In addition to changing these materials, Team 17 recommends that the scale's circuit be redone. Although it functions properly, the circuit would benefit from larger resistors, a second op-amp, an adjustable gain, and a larger potentiometer. These changes would not only make the entire circuit more stable, they would increase battery life and increase the accuracy of the scale. Finally, fixing the weighing platform would prevent it from falling off in the event the scale is turned upside down.

## Appendix

*Equations used throughout assignment:*

$$\text{Strain} = \frac{6F \cdot (x-L)}{b \cdot h^2 \cdot E}$$

$$E = 10000000 \text{ psi}$$

$$\text{Output from Wheatstone Bridge} = \frac{2 \cdot \text{input voltage} \cdot \text{Strain}}{4}$$

Spreadsheets created using these equations:

Input Voltage	18		
Gain	391.7		
Weight (oz)	Strain	Output from Wheatstone Bridge	Final Output
0	0	0	0
8	0.00023	0.0020736	0.812229
16	0.000461	0.0041472	1.624458
24	0.000691	0.0062208	2.436687
32	0.000922	0.0082944	3.248916
40	0.001152	0.010368	4.061146
48	0.001382	0.0124416	4.873375
56	0.001613	0.0145152	5.685604
64	0.001843	0.0165888	6.497833

Lengths	Thickness Of Beam		
	0.0625	0.1250	0.2500
1.00	-0.000614	-0.000154	-3.84E-05
2.00	-0.001843	-0.000461	-0.000115
3.00	-0.003072	-0.000768	-0.000192
4.00	-0.004301	-0.001075	-0.000269

**Strain on Beam at Sizes**

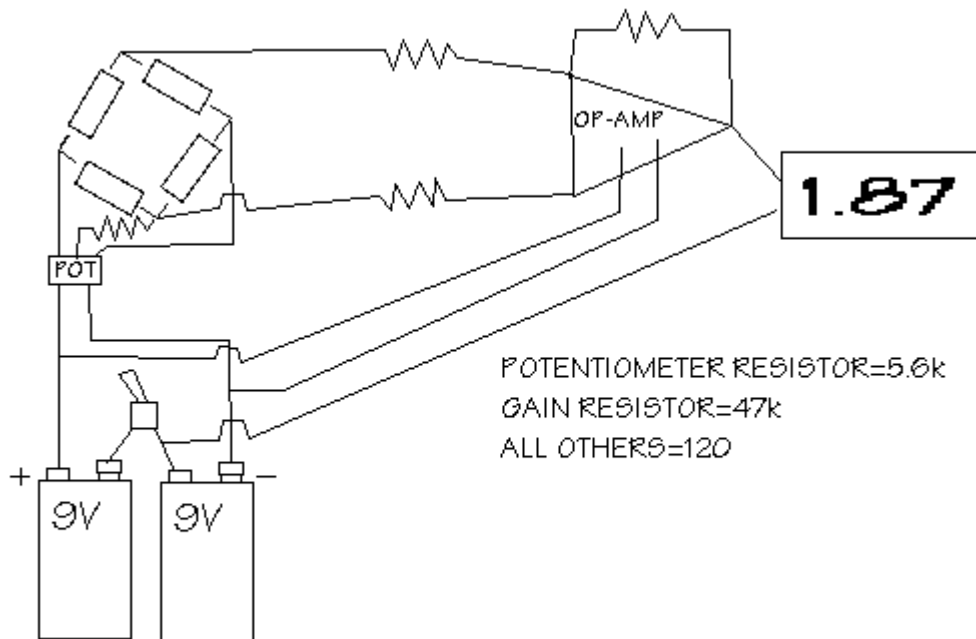

**Circuit Schematic**

## Timeline

