

Leader: David  
Principal Writer: Roshelle  
Adam; David; Eme; Ian

The team-9 design of a human powered pump will consist of a vane pump that is powered by a foot/hand crank. This design will meet all the following criteria:

- 1) It will vertically displace water a distance of eight feet.
- 2) One person will operate the pump at a time for a length of five minutes per person.
- 3) Three different team members, one female and two males will operate the pump.
- 4) The cost of the prototype development and fabrication will not exceed \$125.
- 5) The assembly time for the pump and its components will be no more than 15 minutes and disassembly time will not exceed 10 minutes.

The decision to utilize a vane pump was based on the numerous reports and accounts that the vane pumps could pump more water than any other could. The problem that must be overcome is the lack of efficiency at lower RPMs (Rotations Per Minute). Most centrifugal pumps are effective above 500-700 RPMs. To get an idea of how much this really is you can compare it to a car at idle speed. To use human power to get a pump to revolve at car idle speed seemed a bit of a challenge to our team. The system is powered from a primary wheel (see Pump Drive) that is eight inches in diameter. This wheel is used to power a 1.5-inch diameter wheel (see Pump Drive) that is attached to the water pump by use of a chain from a bicycle. The large wheel rotates at a slower speed than the small wheel. At these dimensions the small wheel will rotate  $5 \frac{1}{3}$  times the RPMs of the large wheel. When pedaled this will give us the high RPMs that are needed to be efficient. One great difficulty in the concept of this pump is that in order for a pump to run at such high rpm, the precision of the components is essential. Pieces that are not correctly machined run the risk of breaking under such high strain, rendering the pump useless. For this reason, we have decided to go with a pump that is already made and incorporate it to be human powered.

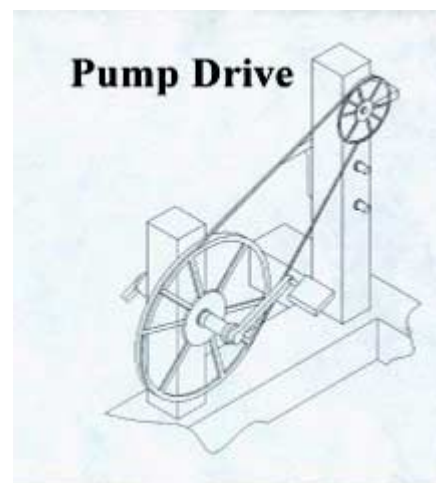

When making the design of the seat assembly, we wanted to allow for a wide range of users. We decided to make it movable by using holes spaced at various distances apart along the ground support beam and a pin that would keep the seat stationary. This system will allow for a large range of movement with little effort in adjusting. It will also be very sturdy. The reason for us wanting a chair with a large range of movement is to make the pump usable for all types. It will be able to be used by someone as small as a child to a full grown adult as well as a person who is unable to use his or her legs to pedal. The adjustable seat will allow for the pedals to be reached with their hands. On the driving gear there will be pedals that your feet apply force to drive the gear much like a bicycle. These pedals will have the ability to be taken off at anytime. This design feature allows us to switch the feet pedals with more comfortable hand pedals for use when the seat is adjusted all the way forward when the pump is being operated by arm power. The driving gear will be raised up enough for one to fit their legs under the pedals to use their hands. We found a medium point at which the driving gear could be pedaled with hands or feet comfortably. This requires the seat to be at a slight angle.

The function of the vane pump is dependant on two main components the impeller and the housing. The housing consists of the volute and the sideplates. Vanes fit within the slots of the impeller. As the impeller rotates sliding vanes draw the liquid in behind the vane with the use of centrifugal force and atmospheric pressure. The flow is composed of a circular motion displacing liquid particles from the inlet port towards the outlet port. A tight seal among the vanes, volute, and sideplates is the key to the good suction. As the impeller continues around, the vanes sweep the fluid to the opposite side of the volute where it is squeezed through discharge port.

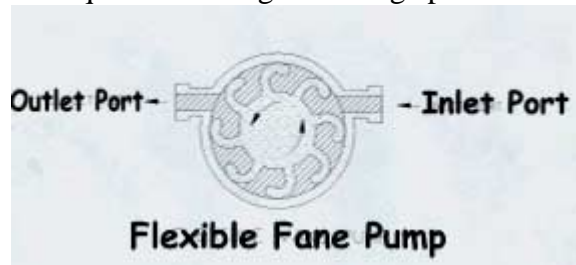

After the pump has forced the water out, it will be channeled up eight feet through a flexible hose. The flexible hose allows the pump to be used in various venues. The end of the hose will be attached to a thin-channeled flume. Here the water will run down the flume and into the holding tank. Half way down the flume a float and a calibrated scale (see Flow Meter) will measure the flow rate. As the water travels down the flume the float rises to the top. The shaft that connects the float will show the flow rate on the calibrated scale opposite the pivot point.

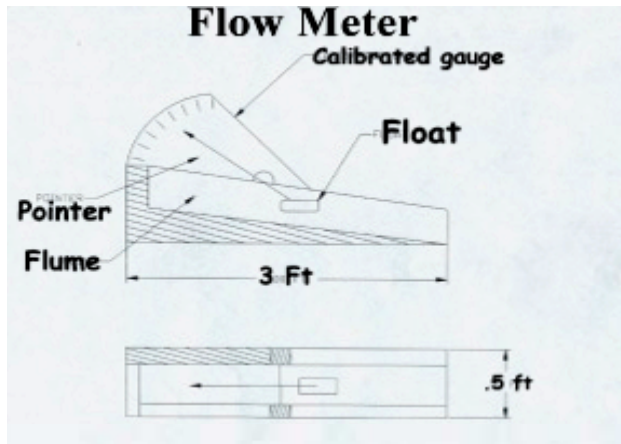

The estimated budget is as shown below (see budget table). Some items in the budget may account for several pieces of the design. Parts like the chain, crank, and gears are all encompassed in the bicycle purchase. Also this estimation is under budget. This allows us to cover unexpected costs that may arise in the future.

Estimated budget	
Item:	Cost:
Bicycle	\$15.00
Pump	\$30.00
Metal bar stock	\$20.00
Lumber	\$10.00
Fasteners	\$5.00
Seat	\$8.00
Hose	\$5.00
Total	\$93.00

Budget table